

S. Arzola-Peralta · J. Genescá Llongueras
M. Palomar-Pardavé · M. Romero-Romo

Study of the electrochemical behaviour of a carbon steel electrode in sodium sulfate aqueous solutions using electrochemical impedance spectroscopy

Received: 8 May 2002 / Accepted: 30 October 2002 / Published online: 5 February 2003
© Springer-Verlag 2003

Abstract The study of a plain carbon steel (AISI 1020) in Na_2SO_4 aqueous solutions at different concentrations was carried out by electrochemical impedance spectroscopy (EIS) in order to determine the corrosion mechanism and to obtain representative corrosion rates of the system. EIS was used to measure corrosion current densities at high concentrations in the range 0.1–1 wt% Na_2SO_4 , but in the low concentration range, from 0.001 to 0.01 wt%, a scattered Nyquist plot was obtained. Other electrochemical techniques, such as polarization resistance (PR), Tafel plots and electrochemical noise (EN), were also used in this analysis. The charge transfer resistance was determined and compared with the PR and noise resistance.

Keywords Corrosion rate · Carbon steel · Sodium sulfate · Electrochemical impedance spectroscopy

Introduction

One of the most important objectives of corrosion research is to provide information about the mechanisms of the corrosion processes that may be taking place and the determination of associated corrosion rates, and the efficiency of corrosion protection achieved by application of adequate materials (alloys and other non-metals), protective layers, coatings and inhibitors, etc. As corrosion processes are of an electrochemical nature, the

electrochemical methods employed play an important role in corrosion research and testing. Several researchers have made significant contributions studying the electrochemical behaviour of metals immersed in diverse electrolytes with different ionic concentrations (or overall resistivities) [1].

After the work by Rojas et al. [2], a thermodynamic predominance zone diagram (PZD) can be constructed in order to determine the stability of the soluble species of interest to our work, as the result of the corrosion of steel in Na_2SO_4 aqueous solutions, according to the following reactions:

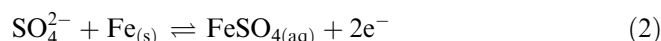

Previously, we have presented results [3, 4, 5, 6] concerning the electrochemical behaviour of plain carbon steel AISI 1020 in sulfate media, where we used polarization resistance, Tafel plots and electrochemical noise. For the latter, we analysed the data in the traditional form, making use of the Fourier transform and the maximum entropy method, also applying chaos data analysis [6, 7, 8] to obtain the Lyapunov exponent and the fractal dimension, and the morphology of strange attractors. The objective was to gather a significant amount of electrochemical information on the system, in particular as the metal plays a well-known role as a construction material in diverse media where the presence of sulfates has not been researched as deeply as we now propose.

Therefore, the present work aims to study the behaviour of the plain carbon steel AISI 1020 in sulfate media using electrochemical impedance spectroscopy to establish the rate-controlling stage of the corrosion mechanism.

Experimental

The electrochemical study of the carbon steel was carried out in a sodium sulfate electrolyte prepared with distilled water at several concentrations: 0.001, 0.01, 0.1, 0.2, 0.4 and 1 wt%. The working

Presented at the XVII Congress of the Mexican Electrochemical Society, 26–31 May 2002, Monterrey, Mexico

S. Arzola-Peralta (✉) · J. Genescá Llongueras
Departamento de Metalurgia, Facultad de Química,
Universidad Nacional Autónoma de México, Edificio D,
Ciudad Universitaria, 04510 Mexico City, Mexico
E-mail: sergioap_72@yahoo.com

M. Palomar-Pardavé · M. Romero-Romo
Departamento de Materiales,
Universidad Autónoma Metropolitana-Azcapotzalco,
02200 Azcapotzalco, Mexico

electrodes were two cylindrical steel bars mounted in a epoxy resin of commercial manufacture, leaving a total exposure area of about 0.332 cm^2 (Fig. 1). Before the electrochemical measurements were

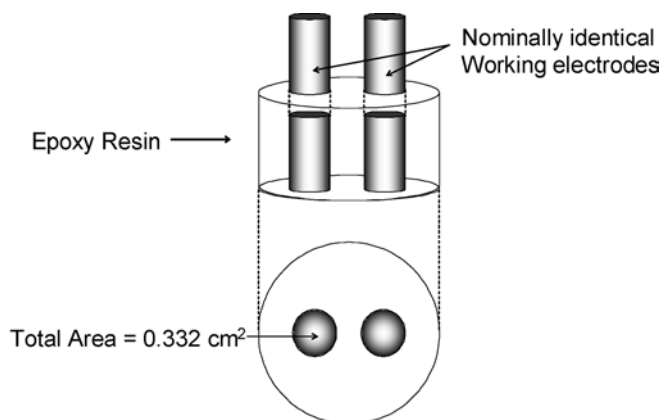

Fig. 1 Arrangement for the two working electrodes

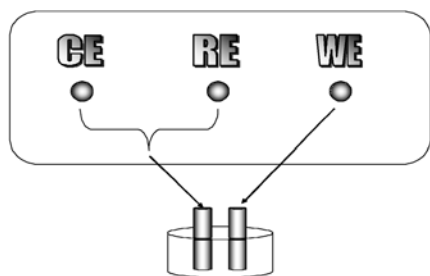

Fig. 2 Electrode arrangement for the EIS technique

Table 1 pH values for the seven conditions evaluated

| Concentration Na_2SO_4 (wt%) | pH |
|--|------|
| 0.0 | 6.96 |
| 0.001 | 6.86 |
| 0.01 | 6.77 |
| 0.1 | 6.76 |
| 0.2 | 6.74 |
| 0.4 | 6.70 |
| 1.0 | 6.64 |

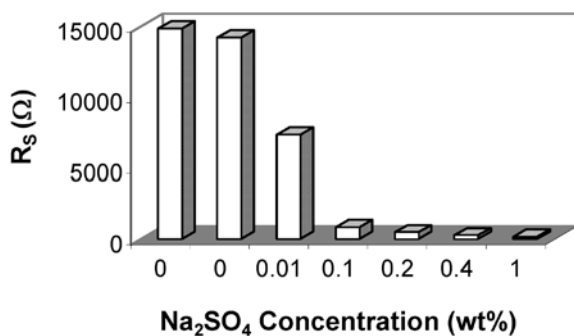

Fig. 3 Variation of the solution resistance, R_s , as a function of Na_2SO_4 concentration

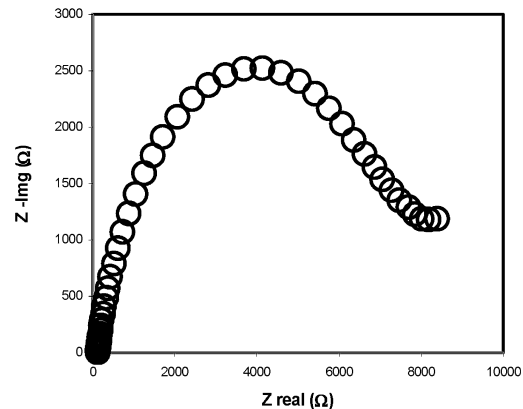
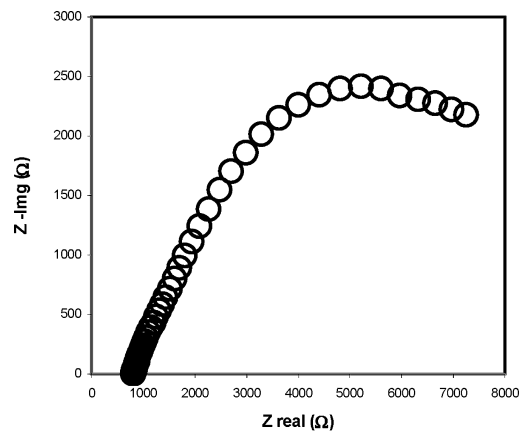
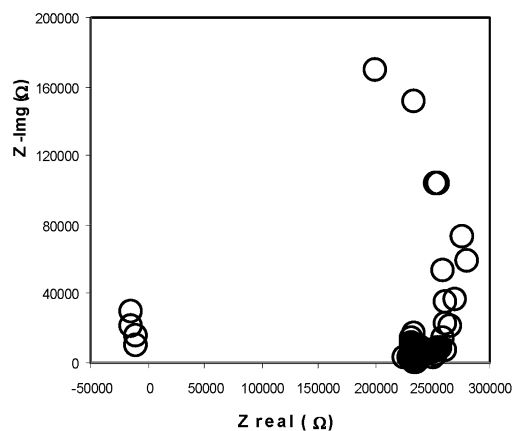

Fig. 4 Nyquist plots for the carbon steel immersed in a sodium sulfate solution. Top left: 0.0 wt%; top right: 0.1 wt%; bottom: 1.0 wt% concentrations

done, the samples were ground with SiC paper 600 grit and mechanically polished down to $0.3 \mu\text{m}$ alumina to obtain a fine polishing. The samples were cleansed in distilled water and degreased in acetone.

The arrangement was such that the three electrodes, the working and reference electrodes, were short-circuited. Experimental control, data acquisition and manipulation were carried out by means of a potentiostat/galvanostat (Gamry Instruments, model PC3) linked to a PC and a lock-in amplifier (Stanford Research System, model SR810 DSP), controlled by software CMS100 (Gamry Instruments) (Fig. 2). The procedure for monitoring was as follows: the mounted samples were immersed in the solution and after 30 min the impedance was measured from an initial frequency of 100,000 Hz to a final frequency of 0.01 Hz, with an amplitude of

Fig. 5 Log $|Z|$ variation vs. log frequency as a function of Na_2SO_4 wt% concentration

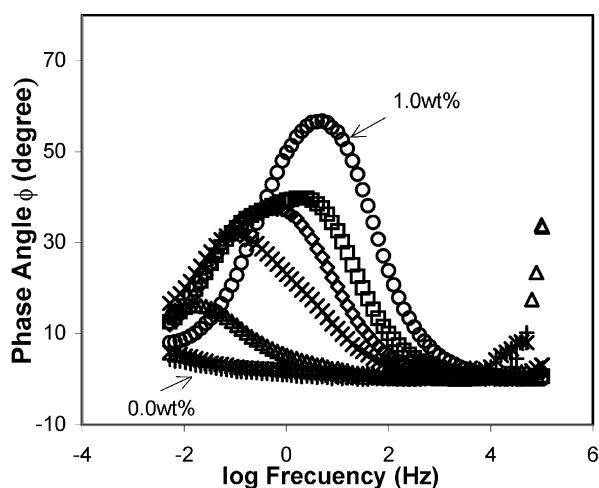
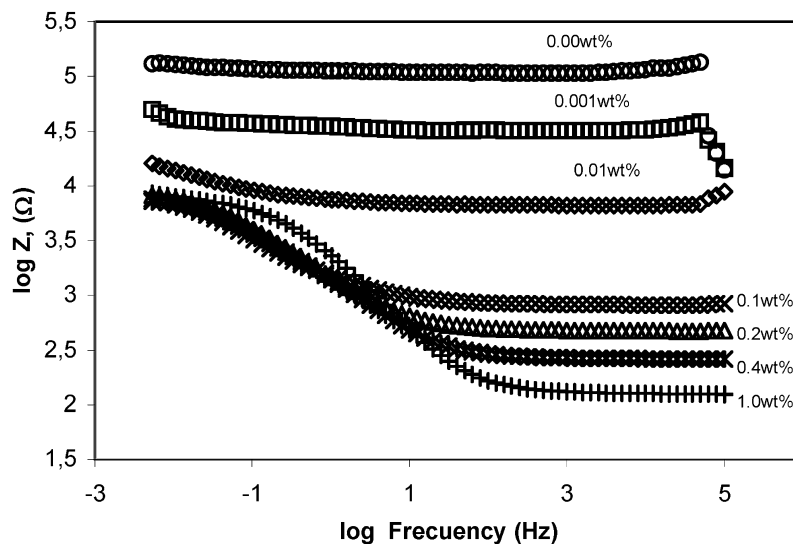

Fig. 6 Phase angle variation vs. log frequency as a function of Na_2SO_4 wt% concentration; first day of monitoring

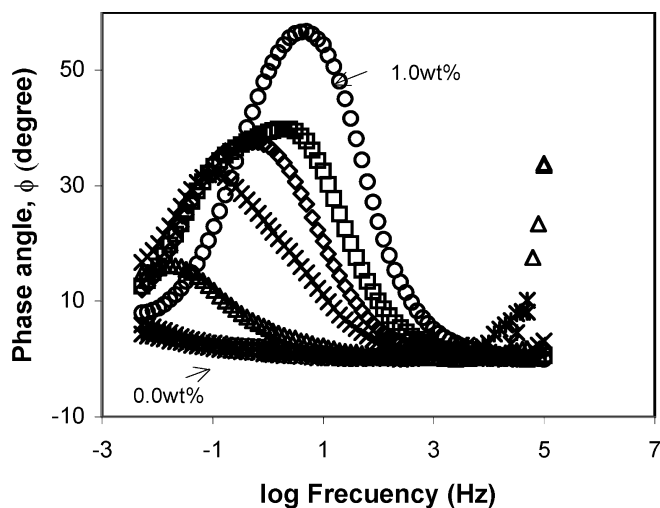

Fig. 7 Phase angle variation vs. log frequency as a function of Na_2SO_4 wt% concentration; seventh day of monitoring

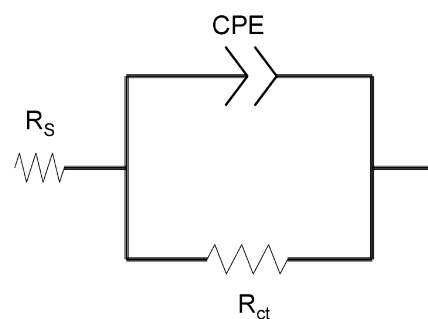

Fig. 8 Randles equivalent circuit with a constant phase element. R_s = solution resistance; CPE = constant phase element; R_{ct} = charge transfer resistance

10 mV (r.m.s.) from E_{corr} . The measurement was repeated daily during a 7-day period. All experiments were carried out at room temperature and atmospheric pressure. Table 1 contains the pH values corresponding to the different conditions studied in this work.

Results and discussion

Nyquist plots for the carbon steel immersed in the sodium sulfate solutions were scattered plots at low concentrations of Na_2SO_4 (lower than 0.1 wt%), which made the analysis of the data difficult. From this concentration it became feasible to analyse the corresponding Nyquist plot for the remainder of the concentration values (higher than 0.1 wt%).

The first parameter determined by both Nyquist and Bode plots was the solution resistance, R_s ; as shown in Fig. 3, this parameter decreases as the Na_2SO_4 concentration increases, having the highest resistance values at low concentrations.

The Nyquist scattered plots at low concentrations become less scattered as the sodium sulfate concentration increased, as shown in Fig. 4. At low sodium sulfate concentrations (0.0, 0.001 and 0.01 wt%), the system

Fig. 9 EIS data fitting for the 0.4 (left) and 1.0 wt% Na_2SO_4 concentrations (right) using a CPE

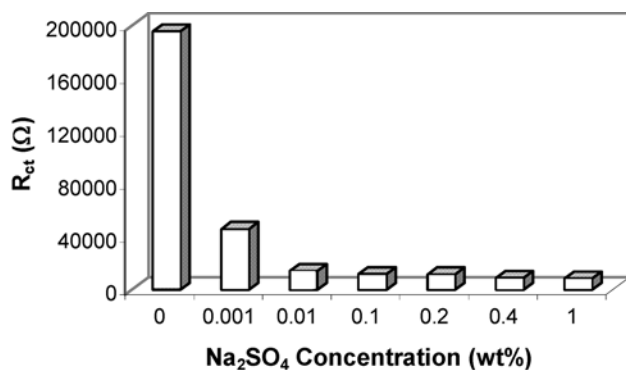
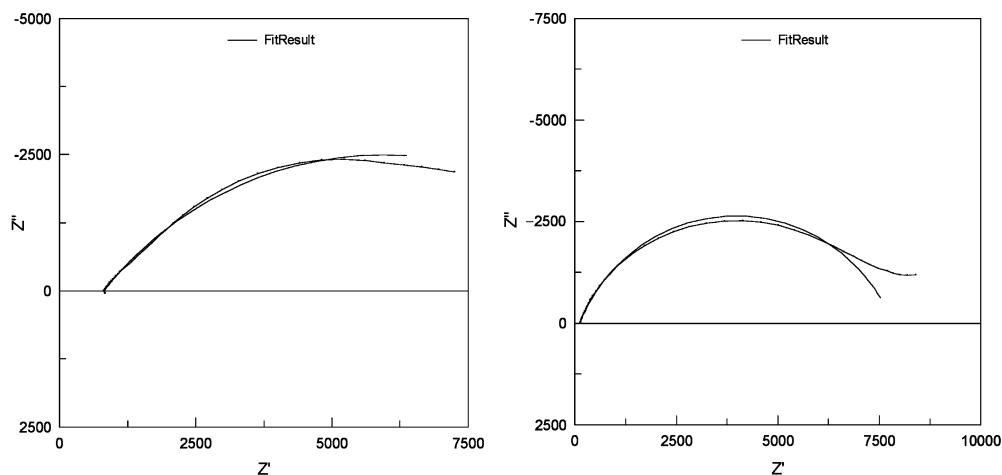

Fig. 10 Charge transfer resistance, R_{ct} , variation vs. sodium sulfate concentration

Table 2 Solution resistance, R_S , and charge transfer resistance, R_{ct} , vs. Na_2SO_4 concentration, obtained using an equivalent circuit containing a CPE

| Na_2SO_4 concentration (wt%) | R_S (Ω) | R_{ct} (Ω) |
|--|--------------------|-----------------------|
| 0.0 | 14,886.85 | 195,528.57 |
| 0.001 | 14,238.57 | 45,770.28 |
| 0.01 | 7352 | 15,144 |
| 0.1 | 848.9 | 11,643 |
| 0.2 | 484.9 | 11,495 |
| 0.4 | 258 | 8731 |
| 1.0 | 172.4 | 8412 |

$\text{Fe-H}_2\text{O-Na}_2\text{SO}_4$ seems to be formed as a pure resistor. However, at high concentrations (higher than 0.1 wt%), a characteristic semicircle was obtained; in principle this semicircle can be attributed to the dissolution of iron.

In terms of the Bode diagram (Fig. 5), this behaviour can be seen as a horizontal line over the whole range of frequencies at low concentrations of sodium sulfate. From the concentration value of 0.1 wt% of Na_2SO_4 the spectrum obtained was that characteristic for the impedance modulus. At this point it became possible to establish the solution resistance and charge transfer resistance values.

Similar behaviour can be seen in the phase angle vs. log frequency plot as a function of the sodium sulfate

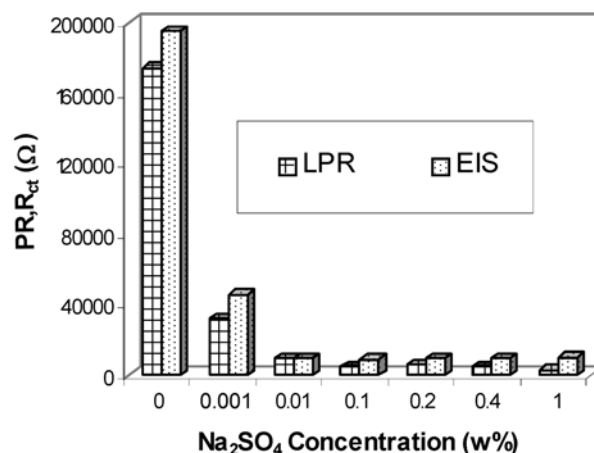

Fig. 11 Qualitative comparison between PR and the charge transfer resistance as a function of Na_2SO_4 concentration

concentration (Figs. 6 and 7). At low Na_2SO_4 concentrations (0.001 wt%), the value of the phase angle is practically zero, reaching the highest value (60° approximately) when the concentration of sodium sulfate was higher (1.0 wt%).

Frequently, a Randles circuit is proposed to simulate the impedance data corresponding to a simple charge transfer process [9]; this model is characteristic of those systems that have only one time constant. However, this is not the case in most of the laboratory impedance results. In the analysis of the EIS data, a Randles equivalent circuit with a constant phase element, CPE (Fig. 8), was used in order to analyse the impedance data obtained, as proposed by Brug et al. [10].

As previously mentioned, at low concentrations of Na_2SO_4 it was difficult to fit the EIS data to a simple equivalent circuit using a capacitor; instead, introduction of a CPE provides a better fitting for the impedance data. Figure 9 shows the EIS data fitted to a CPE corresponding to data shown in Fig. 4.

By introducing a CPE it was also possible to calculate the charge transfer resistance, R_{ct} , as well as the solution resistance, R_S ; the latter is shown in Fig. 3. The variation

Fig. 12 Qualitative comparison of polarization resistance values for three different electrochemical techniques

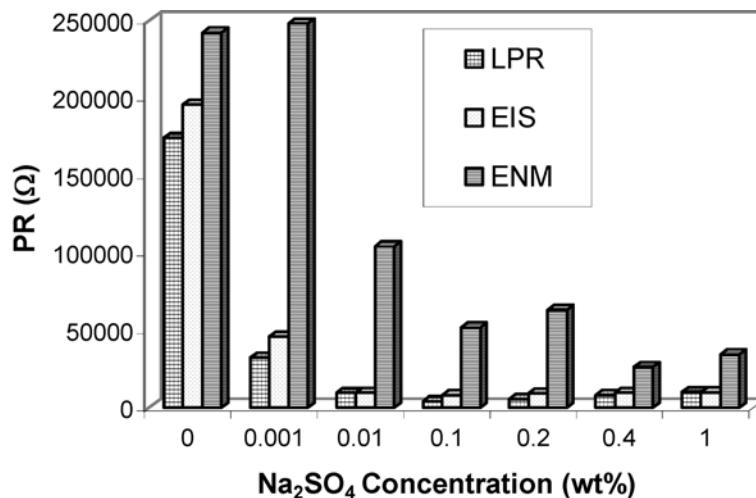

of the charge transfer resistance as a function of the Na₂SO₄ concentration is presented in Fig. 10. The charge transfer resistance and the solution resistance calculated using a CPE are presented in Table 2.

Figure 11 is a qualitative comparison between the values for the polarization resistance and charge transfer resistance. As can be seen in the figure, the trend for both parameters is practically the same. The highest values for these parameters were obtained at zero Na₂SO₄ concentration.

Figure 12 shows a quantitative comparison between the different techniques: linear polarization resistance (LPR), electrochemical noise (EN) and EIS. It is possible to note on this figure that the highest value for the polarization resistance was estimated by the EN technique. Although the three techniques had a similar trend, they presented very different values. Theoretically, the technique that better describes the corrosion phenomenon is the weight loss because this represents the

real conditions of corrosion. However, in this work we consider that the electrochemical technique that better describes the corrosion of iron immersed in Na₂SO₄ solutions is that which takes into account the ohmic drop. For this reason, the electrochemical spectroscopy impedance gives a good approximation to the real corrosion rates for the proposed system.

Corrosion mechanism

The morphology of the corrosion attack occurring on the surface of the mild steel after a 7-day exposure can be regarded as partially uniform. This attack started in isolated locations and spread laterally without developing any pits. Other authors, for example Thomas et al. [11], found that the corrosion process is uniform and the formation of a FeSO₄ ion pair complex is found in the presence of SO₄²⁻ ions only. As pointed out by Gui and

Fig. 13 Variation of the open circuit potential, E_{corr} , vs. time exposure: 0.0 wt% Na₂SO₄ (open circles) and 1.0 wt% Na₂SO₄ (solid circles)

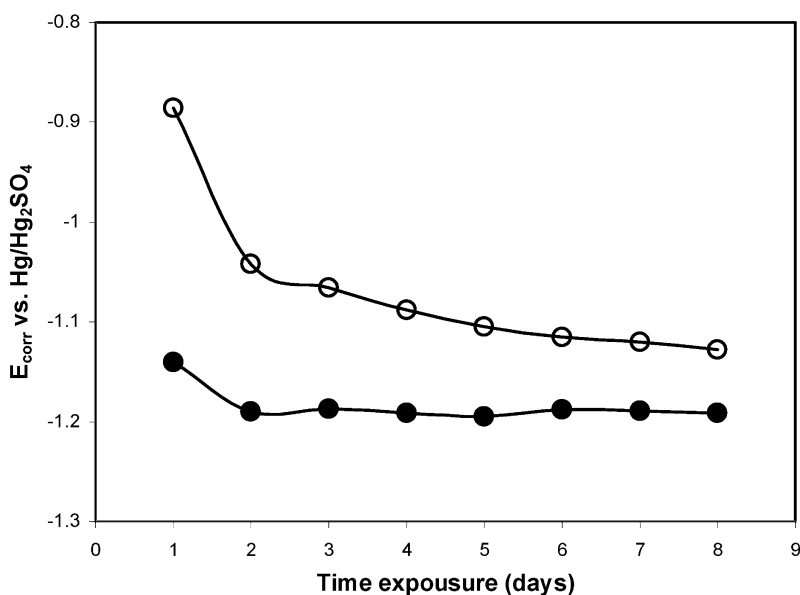

Devine [12], the effect of SO_4^{2-} on the rate of oxidation of iron in mildly alkaline solutions results from its ability to form soluble complexes with either Fe^{2+} or Fe^{3+} ions. The cyclic voltammogram of iron in these solutions suggests that dissolution of the metal is the major anodic process [13]. Florianovitch et al. [14] found that sulfate ions accelerate the active dissolution of iron, and other workers [15] concluded that the films formed in sulfate solutions ($\text{pH} \approx 7$) result from supersaturated solutions of iron salts, most probably iron hydroxysulfate. This implies that iron dissolves in sulfate solutions at a high rate, creating a supersaturated solution and allowing precipitation of a film. These films were found [15] to be nonprotective.

Under the study conditions evaluated here, oxygen reduction is the prevailing cathodic reaction, because all experiments were conducted under no-oxygen control conditions. At $\text{pH} \approx 7$ the oxygen reduction is expressed by the equilibrium:



On the other hand, the "air-formed film" may not be stable under the study conditions used here. After the polishing, the surface of the steel was in contact with air and then an "air-formed film" is present. However, as soon as the steel makes contact with the solution, this film is dissolved. This is demonstrated by the open-circuit potential values shown in Fig. 13.

Conclusions

The corrosion of mild steel in Na_2SO_4 solutions takes place according to:

For values < 0.1 wt% Na_2SO_4



and:

For values ≥ 0.1 wt% Na_2SO_4

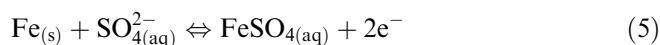

The corrosion rate of AISI 1020 mild steel increases significantly above 0.1 wt% Na_2SO_4 .

EIS diagrams do not give relevant information about the proposed mechanism because at low concentrations

a scattered Nyquist plot was obtained. The impedance diagrams shown a capacitive semicircle which is characteristic of a charge transfer process, especially for the higher concentrations studied; the behaviour is purely resistive for the lower concentrations.

R_p values determined from EIS follow a behaviour very similar to than obtained by LPR and EN, showing an important decrease under 0.01% Na_2SO_4 . Taking into account the ohmic drop, EIS is the technique that better describes the corrosion of steel in Na_2SO_4 containing solutions.

References

1. Cottis RA, Turgoose S, Mendoza-Flores J (1994) Technical paper. Corrosion and Protection Centre, UMIST, UK
2. Rojas A, Ramírez MT, Ibáñez JG, González I (1991) *J Electrochem Soc* 138: 365
3. Arzola S, Vázquez-Coutiño G, Palomar-Pardavé M, Romero-Romo M, Genescá J (2001) In: Sinclair JD, Kalman E, Kending M, Plieth W, Smyrl WH (eds) Corrosion and corrosion protection. Joint international meeting, The Electrochemical Society (200th meeting) and the International Society of Electrochemistry (52nd meeting), San Francisco. (Proceedings vol 2001-22) The Electrochemical Society, Pennington, NJ, USA, pp 1032–1043
4. Arzola S, Palomar M, Genescá J (2001) In: 5th electrochemical impedance spectroscopy symposium, Marilleva Trento, Italy, pp 223–225
5. Arzola S, Genescá J, Palomar-Pardavé M (2000) In: XV Congreso de la Sociedad Mexicana de Electroquímica, México, paper COR89
6. Arzola S, Vázquez-Coutiño G, Palomar-Pardavé M, Genescá J, Romero-Romo M (2001) In: XVI Congreso de la Sociedad Mexicana de Electroquímica, Santiago de Querétaro, México, paper COR10
7. Legat A, Dolecek V (1995) *J Electrochem Soc* 6:142
8. Stringer J (1993) *J Corros Sci* 4:35
9. Rowlands JC, Mansfeld F (1986) *Dechema Monographs*, vol 101. Dechema, Frankfurt
10. Brug GJ, Van Den Eeden AL, Sluyters-Rehbach M, Sluyters JH (1984) *J Electroanal Chem* 176:275
11. Thomas JG, Mercer AD, Davies JD (1983) In: Heusler RH (ed) Proceedings of the international conference on corrosion inhibition, p 89
12. Gui J, Devine TM (1995) *Corros Sci* 37:1177
13. Pound BG, Wright GA, Sharp RM (1989) *Corrosion* 45:386
14. Florianovitch GM, Sokolova LA, Kolotyркиn YaM (1967) *Electrochim Acta* 12:879
15. Szklarska-Smialowska S, Mrowczynski G (1975) *Br Corros J* 10:187